

Functional Specifications:

RFID Protocol:	EPC Class1 Gen2, ISO18000-6C
Frequency:	Global 860MHz ~ 920MHz
IC type:	NXP UCODE 8
Memory:	EPC 128 bits, USER 0 bits, TID 96 bits
Write Cycles:	100,000 times
Functionality:	Read/write
Data Retention:	50 Years
Applicable Surface:	Metal Surfaces
Read Range : (Fix Reader)	4.9m, (US) 902-928MHz, On Metal; 5.6m, (EU) 865-868MHz, On Metal;
Read Range : (Handheld Reader)	2.7m, (US) 902-928MHz, On Metal; 2.9m, (EU) 865-868MHz, On Metal.
Warranty:	1 Year

Physical Specification:

Size:	41.0x29.0mm, Hole: D2.3mmx4
Thickness:	11.8mm
Material:	PPS
Colour:	Black
Mounting Methods:	Screw - Socket head cap screw(M2)
Weight:	21.0g

Dimensions:

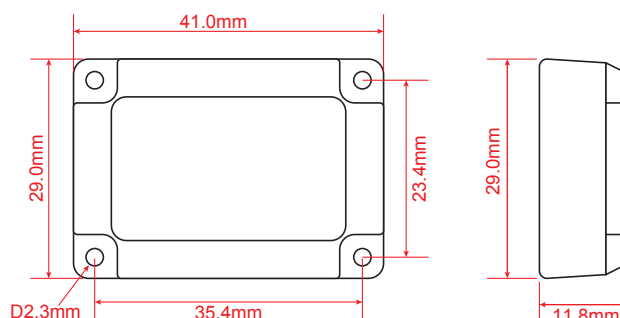

Devil-3002S:

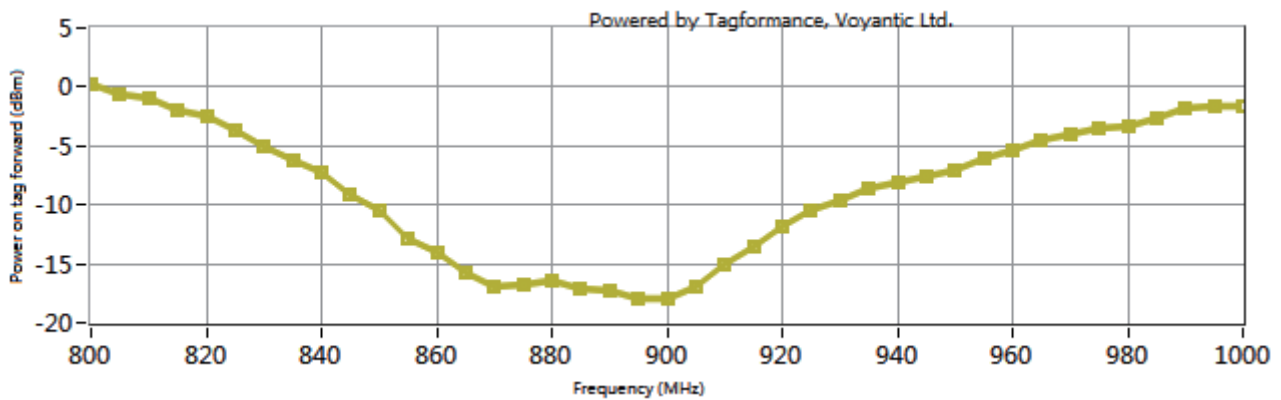
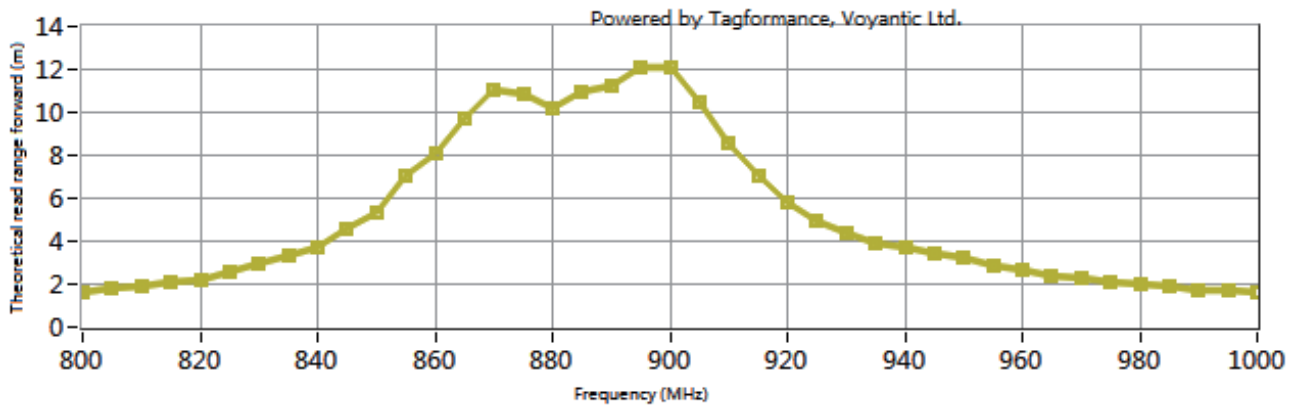

Environmental Specification:

IP Rating:	IP68, IP69K
Withstand PH:	PH0 to PH14, and all other liquid that PPS can handle with.
Storage Temperature:	-60°C to +180°C
Operation Temperature:	-40°C to +150°C
Compression strength:	150Mpa
Certifications:	Reach Approved, RoHS Approved, CE Approved.